



MP8745 Multimedia Projector

Operator's Guide

MP8745 Projecteur multimédia Guide de l'opérateur

MP8745 Multimedia-Projektor Benutzerhandbuch

Projector de Multimedia MP8745 Manual del Usuario

MP8745 Proiettore Multimediale Manuale dell'operatore

MP8745 Bruksanvisning för multimediprojektor

MP8745 Multimedia Projector Gebruiksaanwijzing

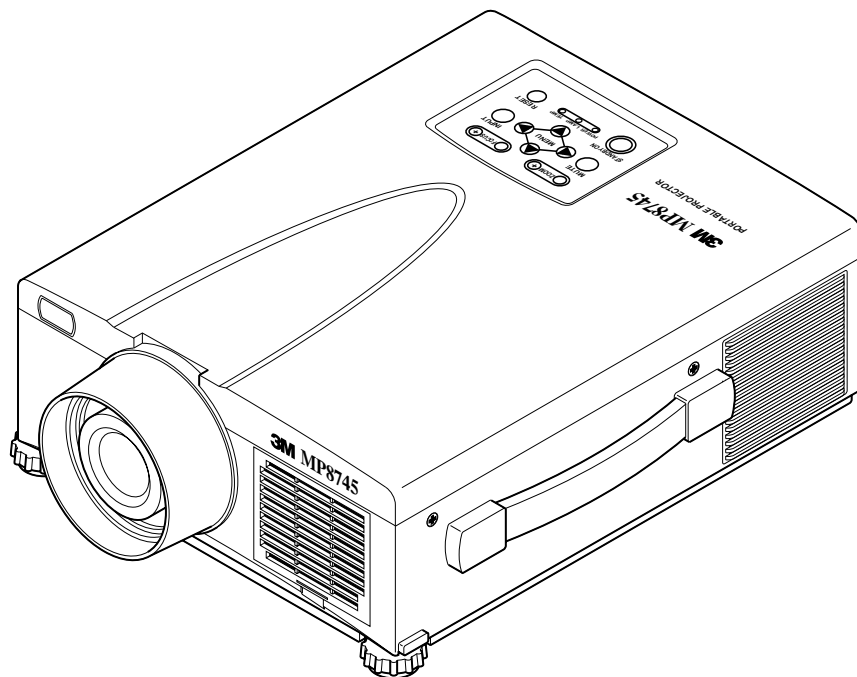



MP8745 Table of Contents

- Safeguards** 3
- Warranty** 5
- Section 1: Unpack** 6
 - 1.1 Contents of Shipping Box 6
 - 1.2 Optional Accessories 6
 - 1.3 Keep Your Packing Materials 6
 - 1.4 What's Next? 6
- Section 2: Product Description** 7
 - 2.1 Machine Characteristics 7
 - 2.2 Part Identification List 8
 - 2.3 System Setup - Connecting Various Equipment 9
 - 2.4 Remote Control Transmitter Identification 11
- Section 3: Basic Operations** 12
 - 3.1 Projector Startup 12
 - 3.2 Projector Shutdown 12
- Section 4: Adjustments and Functions** 13
 - 4.1 How To Use Height Adjustment Feet 14
 - 4.2 Plug & Play - Function 14
 - 4.3 Freeze Function 14
 - 4.4 Magnify Function 14
 - 4.5 Picture-in-Picture 14
 - 4.6 Menu Navigation 15
 - 4.7 SETUP 16
 - 4.8 INPUT 17
 - 4.9 IMAGE 18
 - 4.10 OPT 19
- Section 5: Maintenance** 20
 - 5.1 Cleaning the Air Filter 20
- Section 6: Lamp** 21
 - 6.1 Lamp 21
 - 6.2 Display Lamp Operation Hours 21
 - 6.3 Reset Lamp Hours 21
 - 6.4 Replacing the Lamp 22
- Section 7: Troubleshooting** 23
 - 7.1 Symptom/Solution Table 23
 - 7.2 Message/Solution Table 23
- Section 8: Service Information** 24
- Appendix: Technical Information** A-1



Safeguards

INTENDED USE

Before operating the machine, please read the entire manual thoroughly. The 3M™ Multimedia Projector 8745 was designed, built and tested for use indoors, using 3M™ brand lamps, 3M™ brand ceiling mount hardware and nominal local voltages. This projector is not intended for household use. The use of other replacement lamps, outdoor operation or different voltages has not been tested and could damage the projector or peripheral equipment and/or create a potentially unsafe operating condition.

IMPORTANT SAFEGUARDS

1. Read and understand all instructions before using.
Pay particular attention to areas where this ⚠ symbol is shown.

⚠ WARNING - Indicates a potentially hazardous situation which, if not avoided, could result in death or serious injury.

⚠ Caution - Indicates a potentially hazardous situation which, if not avoided, could result in minor or moderate injury. It may also be used to alert against unsafe practices.

✓ **Note** - Used to emphasize important conditions or details.

2. Close supervision is necessary when any appliance is used by or near children. Do not leave appliance unattended while in use.
3. Never look directly into the projector lens when the lamp is on. The high pressure mercury lamp produces a strong light which could damage your eyesight.
4. Care must be taken as burns can occur from touching hot parts.
5. Do not operate appliance with a damaged cord or if the appliance has been dropped or damaged – until it has been examined by a qualified service technician.
6. Position the cord so that it will not be tripped over, pulled, or contact hot surfaces.
7. If any extension cord is necessary, a cord with a current rating at least equal to that of the appliance should be used. Cords rated for less amperage than the appliance may overheat.
8. Always unplug appliance from electrical outlet before cleaning and servicing and when not in use. Grasp plug and pull to disconnect.
9. To reduce the risk of electric shock, do not immerse this appliance in water or other liquids.
10. To reduce the risk of electric shock, do not disassemble this appliance, but take it to a qualified technician when service or repair work is required. Incorrect assembly can cause electric shock when the appliance is subsequently used.
11. Connect this appliance to a grounded outlet.
12. Do not expose this projector to direct sunlight, or use it outside.
13. Keep all ventilation openings free of any obstructions.
14. Always open the lens shutter or remove lens cap when the projection lamp is on.
15. Do not look directly into light beam of laser pointer. The pointer produces a strong light which could damage your eyesight.
16. The projection lamp contains mercury. Always dispose of it in a proper manner according to local regulations.
17. To avoid premature lamp failure, do not change the mounting position of the projector (desktop ⇨ ceiling mount or ceiling ⇨ desktop mount) and continue to use the same lamp.
18. Always operate machine on a flat, sturdy surface.

LOCATION OF PRODUCT SAFETY LABELS

The following safety labels are used on or within the MP8745 projector to alert you to items or areas requiring your attention:

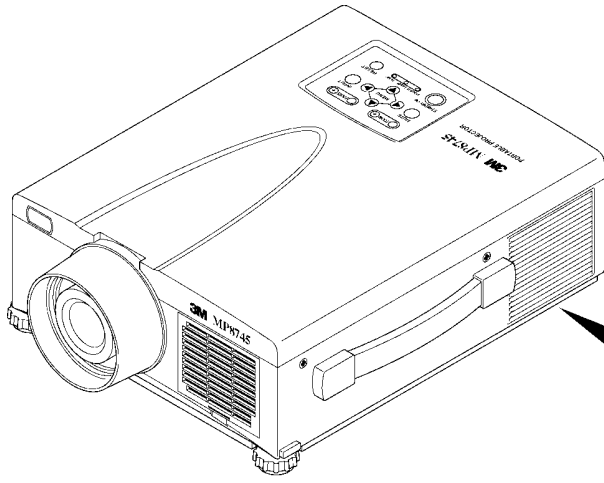

⚠ 🔥 **HIGH TEMPERATURE / HAUTE TEMPERATURE / HOCHTEMPERATUR / ALTA TEMPERATURA / ALTA TEMPERATURA** 3M

- When replacing lamp, turn off and unplug unit, wait 45 minutes to let lamp cool. High-pressure lamp when hot, may explode if improperly handled.
- Pour changer la lampe, éteindre et débrancher la machine. Attendre 45 minutes de manière à laissez refroidir la lampe. La lampe haute pression risque d'exploser si elle est manipulée sans précaution lorsqu'elle est encore chaude.
- Vor Austausch der Lampe, das Gerät abschalten und den Stecker herausziehen; 45 Minuten warten, um die Lampe abkühlen zu lassen. Falls die heiße Hochdrucklampe falsch gehandhabt wird, kann sie explodieren.
- Prima di sostituire la lampadina, spegnere il proiettore, scollegare la presa di alimentazione ed attendere 45 minuti circa che la lampadina si raffreddi. Se calda, essa è sottoposta ad alta pressione interna e può esplodere.
- Cuando tenga que reemplazar la lámpara, desconecte la alimentación y desenchufe la unidad, y espere 45 minutos para dejar que se enfrie la lámpara. La lámpara, que está a alta presión cuando está caliente, puede explotar si se manipula indebidamente.

QL06982

CAUTION

LASER RADIATION
DO NOT STARE INTO BEAM

WAVE LENGTH: 670 nm
MAX. OUTPUT: 1mW
CLASS II LASER PRODUCT

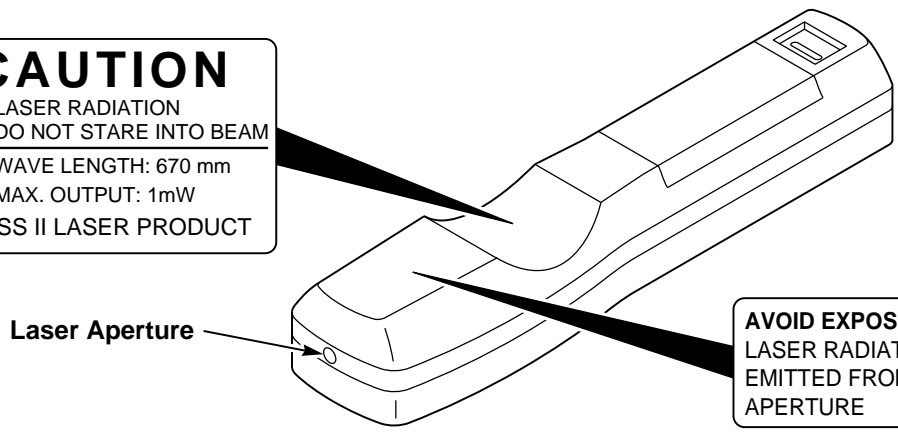

AVOID EXPOSURE-
LASER RADIATION IS
EMITTED FROM THIS
APERTURE

SAVE THESE INSTRUCTIONS

The information contained in this manual will help you operate and maintain your 3M MP8745 Multimedia Projector.



Warranty

LIMITED WARRANTY

3M warrants this product against any defects in material and workmanship, under normal usage and storage, for a period of two years from date of purchase. Proof of purchase date will be required with any warranty claim. In the event this product is found to be defective within the warranty period, 3M's only obligation and your exclusive remedy shall be replacement of any defective parts (labor included).

To obtain warranty service, immediately notify the dealer from which you purchased the product of any defects. In the USA call 1-800-328-1371 for warranty or repair service.

LIMITATION OF LIABILITY

THE FOREGOING WARRANTY IS MADE IN LIEU OF ALL OTHER WARRANTIES, EXPRESSED OR IMPLIED, AND 3M SPECIFICALLY DISCLAIMS ANY IMPLIED WARRANTY OF MERCHANTABILITY AND FITNESS. 3M SHALL NOT BE LIABLE FOR ANY DAMAGES, DIRECT, CONSEQUENTIAL, OR INCIDENTAL, ARISING OUT OF THE USE OR INABILITY TO USE THIS PRODUCT.

Important: The above warranty shall be void if the customer fails to operate product in accordance with 3M's written instructions. This warranty gives you specific legal rights and you may have other rights which vary from state to state.

FCC STATEMENT - CLASS A: This equipment generates, uses and can radiate radio frequency energy, and if not installed and used in accordance with the instruction manual may cause interference to radio communications. It has been tested and found to comply with the limits for a Class "A" computing device pursuant to Subpart B of Part 15 of the FCC Rules, which are designed to provide reasonable protection against such interference when operated in a commercial environment. Operation of this equipment in a residential area is likely to cause interference in which case the user at his/her own expense will be required to take whatever measures may be required to correct the interference.

EEC STATEMENT: This machine was tested against the 89/336/EEC (European Economic Community) for EMC (Electro Magnetic Compatibility) and fulfills these requirements.

Video Signal Cables: Double shielded coaxial cables (FCC shield cable) must be used and the outer shield must be connected to the ground. If normal coaxial cables are used, the cable must be enclosed in metal pipes or in a similar way to reduce the interference noise radiation.

Video Inputs: The input signal amplitude must not exceed the specified level.

PATENTS, TRADEMARKS & COPY RIGHTS

IBM is a registered trademark of **International Business Machines Corporation**. **Apple Macintosh** and **Apple Powerbook** are registered trademarks of **Apple Computer, Inc.** **Microsoft** and **Windows 95 & Windows 98** are registered trademarks, and **Windows** and **Windows for Workgroups** are trademarks of the **Microsoft Corporation**. **Toshiba** is a registered trademark of **Toshiba Corporation**. **Kensington** is a trademark of **Kensington Corporation**. All other products are trademarks or registered trademarks of their respective companies.



Section 1: Unpack

1.1 Contents of Shipping Box

The 3M™ MP8745 Multimedia Projector is shipped with the necessary cables required for standard VCR, PC, MAC™ II or laptop computer connections. Carefully unpack and verify that you have all of the items shown below in Figure 1.1.

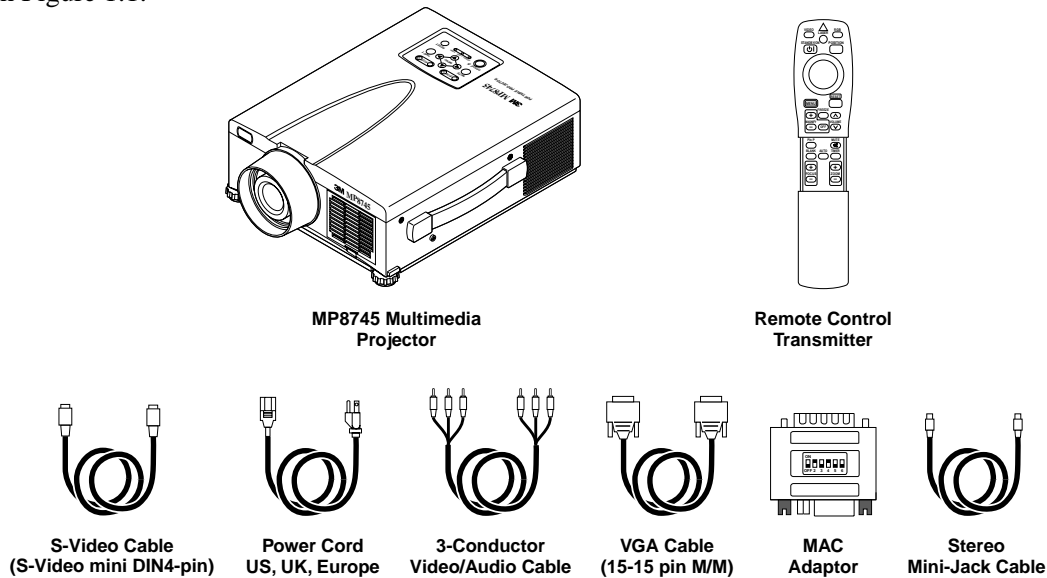

Figure 1.1 Inventory of Shipping Box

The shipping carton contains the items illustrated in Figure 1.1. In addition, the following items are also included, but not shown here. If any of these items are missing, please contact your place of purchase.

- PS/2 mouse cable (1)
- ADB mouse cable (1)
- Serial mouse cable (1)

1.2 Optional Accessories

- RS-232 control cable (1)
- USB mouse cable (1)

1.3 Keep Your Packing Materials

✓ Important

Save the shipping box and packing materials in the event the MP8745 should require shipping to a 3M Service Center for repair.

1.4 What's Next?

After you have unpacked the MP8745 system and identified all the parts, you are ready to set up the projector.

We hope you will enjoy using this high performance product in your meetings, presentations and training sessions.

This product has been produced in accordance with 3M's highest quality and safety standards to ensure smooth and trouble free use in the years to come.



Section 2: Product Description

2.1 Machine Characteristics

The MP8745 Multimedia Projector integrates ultra-high bright lamp and polysilicon LCD display technology into a single unit. It accepts input from two different computer sources and one video/audio source and projects a bright, super crisp image. Switching your presentation from a computer input to a video input, and then back to a computer input simply requires the push of a button on the remote control keypad or control panel keypad.

The MP8745 Multimedia Projector offers the following features:

- UHB (ultra-high bright) projection lamp
- XGA resolution (3 separate 1024 x 768 LCD panels are used for the R, G and B signals)
- Intelligent XGA scaling (60 Hz and 75 Hz)
- Intelligent VGA scaling
- Compact size, light weight for portability
- RGB (computer video) output terminal
- USB, Serial, PS/2 and Apple Desktop Bus (ADB) mouse emulation
- Power zoom and power focus functions
- 4x digital magnification
- Easy to set up and use
- Ability to display 16.7 million colors
- Two computer input connection
- One video input connections (composite and S-video compatible)
- Full function remote control
- Two built-in stereo speakers (1 watt each)
- Horizontal and vertical image inverting function
- Horizontal and vertical image position control
- Digital keystone correction
- On screen menu with eight languages
- Universal power supply
- IR sensor in front and rear for maximum remote control range
- RS-232 control capability
- Optional ceiling mount kit
- Laser pointer (remote control)
- Color balance control for data/video
- Mounting holes for optional document camera
- Plug & Play compatible
- Picture-in-Picture (PinP)
- Freeze function
- Kensington™ Slot  (Kensington microsaver needed)

✓ Note

The MP8745 is one of the brightest portable projectors in the marketplace. The brightness of your machine will vary depending on the ambient room conditions and contrast/brightness settings.

2.2 Part Identification List

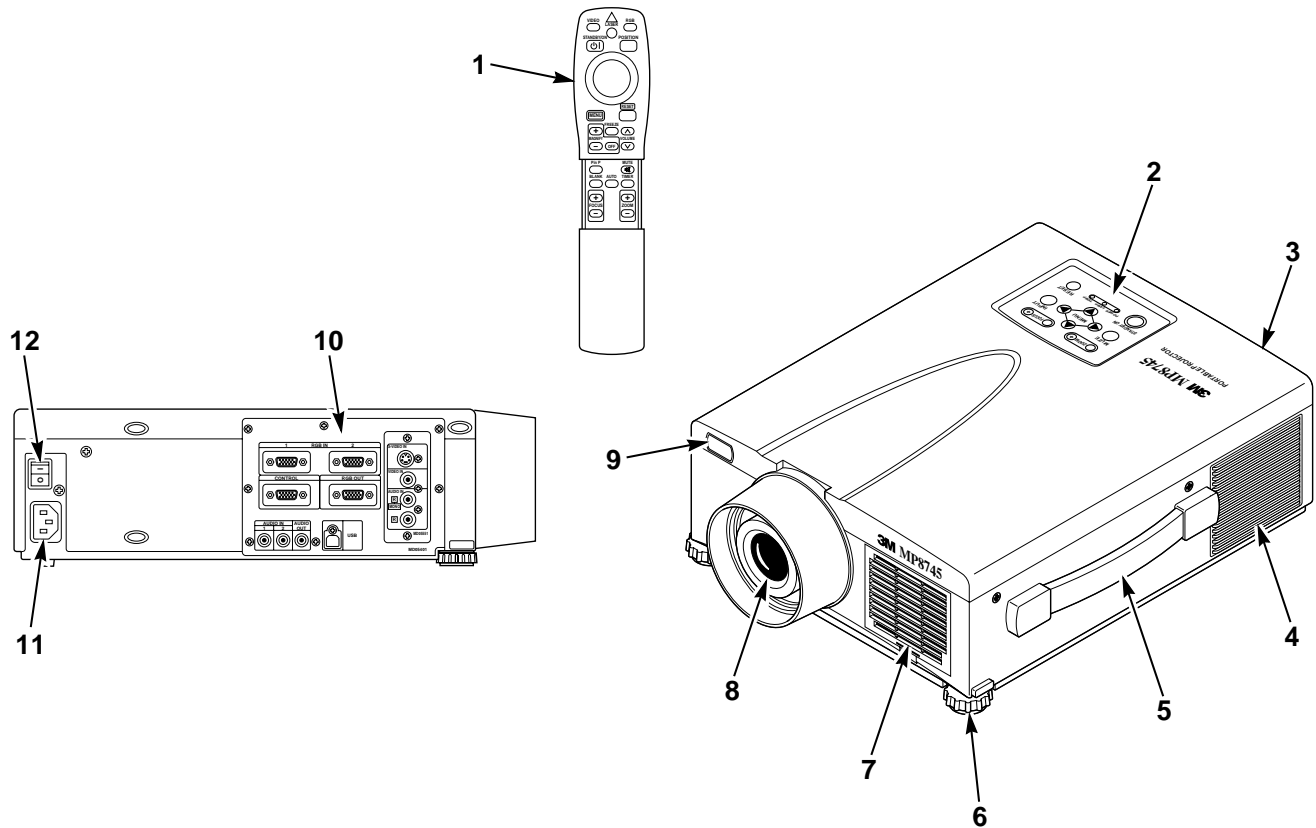

Figure 2.1 Identifying MP8745 Parts

- | | |
|--|---|
| <ol style="list-style-type: none"> 1. Remote control transmitter 2. Control panel keypad <ol style="list-style-type: none"> a) STANDBY/ON button b) POWER, LAMP, TEMP Indicators c) INPUT, MUTE, RESET buttons d) MENU buttons 3. Stereo speakers 4. Cooling fan exhaust 5. Carry handle 6. Height adjustment feet 7. Air filter cover 8. Projection lens | <ol style="list-style-type: none"> 9. Remote control sensors (front/back) 10. Terminal connection panels <ol style="list-style-type: none"> a) S-Video, Video, Audio inputs b) RGB1 and RGB2 inputs c) RGB output d) Audio L/R input, Audio output (stereo mini jack) e) RS-232, PS/2, Serial, ADB Control f) USB Port (must use USB mouse cable, optional) 11. AC input-power cord connection 12. Main power switch |
|--|---|

2.3 System Setup - Connecting Various Equipment

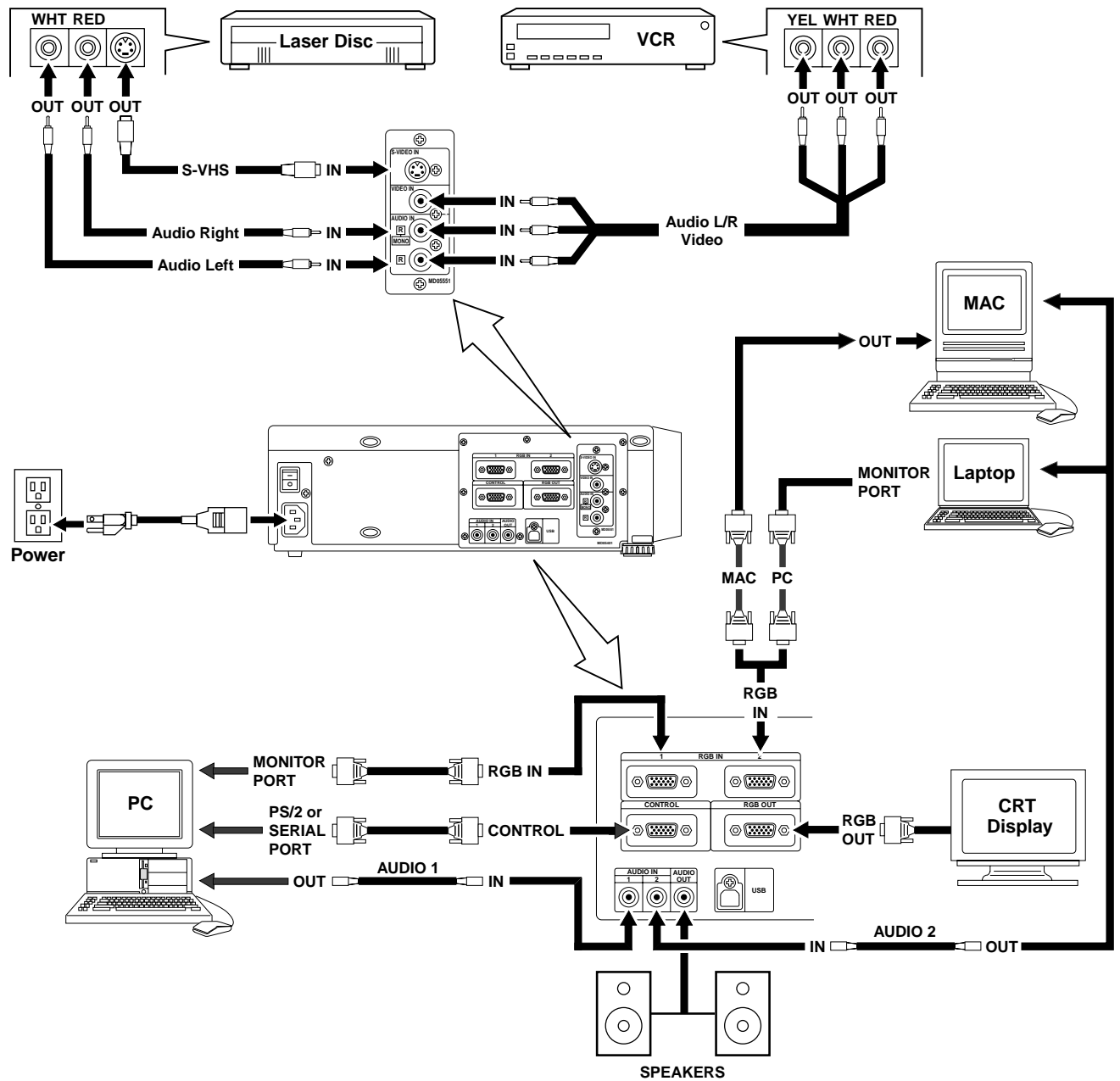

Figure 2.2 Cable Connections

Caution

Turn power off to all devices before making connections. Never plug anything into the projector or computer while any device is in operation.

The MP8745 must be powered down when making connections. The mouse emulation may not work if the unit is not powered down before the mouse cable connections are made.

2.3 System Setup - Connecting Various Equipment (continued)

Apple™ Desktop Mouse - The Macintosh operating system should recognize the MP8745 as a mouse without any drivers being loaded.

VirtualMouse for PC Computer - For IBM™ compatible computers, the operating systems will need to be set to "Serial Mouse," "PS/2 Mouse," or "USB Mouse" to recognize the projector as a mouse pointer device.

Change mouse driver information to "Serial Mouse," "PS/2 Mouse," or "USB Mouse."

- a) **Windows™ 95/Windows™ 98** - Click "Start;" select "Settings;" select "Control Panel." Click on "Mouse;" select the "General" tab; (see what driver is currently loaded and make note of it); select "Change;" select "Show all devices;" (make note of the current Manufacturer and Model); select "Standard Mouse Type" for Manufacturer; then select "Standard Serial Mouse," "Standard PS/2 Mouse," or "USB Mouse." Click OK to change and apply the new driver. Restart Windows if prompted. *USB mouse emulation is not supported in all versions of Windows 95.*
- b) **Windows™ 3.1** - From "Program Manager" click "Main;" then click "Windows Setup," (make note of what the current mouse driver is); Click "Options;" then "Change Systems Settings." Choose "Mouse." It should be listed as "Microsoft or IBM PS/2." *USB mouse emulation is not supported in Windows 3.1.*

✓ Note

For proper mouse operation, always turn the projector power on first and then power up the computer.

For some laptop computers you may need to disable the internal pointing device (IPD). This is done through the BIOS level set up of the particular machine, or it could be listed in a "Utilities" program group, i.e., "Toshiba Utilities™," or "Thinkpad Features™."

2.4 Remote Control Transmitter Identification

INPUT

Press the VIDEO or RGB button to select the input source. Press again to select the next source.

STANDBY/ON

Set main power switch to ON. Press STANDBY/ON button to begin projection mode (lamp on) or press and hold button for 1 second to switch to standby mode (lamp off).

LEFT MOUSE

Press for left mouse button function (located on back of remote).

DISC PAD*

For menu screens, press DISC PAD to select menu items. For non-menu screens, press DISC PAD for mouse shift or left mouse button function.

MENU*

Press to display the menu screen and light the remote control buttons. The button light automatically turns off.

MAGNIFY*

Press the MAGNIFY (+) to enlarge the center of the display image. Press again to enlarge image to maximum of 4X magnification. Press MAGNIFY (-) to reduce the display image size. Press OFF to return to normal image size. (Can be used with the POSITION button to select the image area being magnified.)

PinP*

Press the PinP button to display a video signal as a small picture-in-picture screen in the corner of an RGB display. Press it again to enlarge the picture-in-picture screen size. Press it a third time to exit the PinP screen and turn the function OFF. The position of the picture-in-picture screen can be controlled by pressing the POSITION button or from the Image menu. (Both RGB and Video signals must be present for the picture-in-picture screen to operate.)

BLANK ON

Press button to turn ON/OFF the screen blanking function.

FOCUS

Press (+) or (-) to adjust the image sharpness.

LASER

Press and hold down button to project laser pointer.

CAUTION

To prevent injury to eyesight, do not point laser beam at other persons or look directly into laser beam.

POSITION*

Press button then use DISC PAD to move image (RGB signal only) up/down or left/right.

RESET*/LEFT MOUSE BUTTON

For menu screens, press button to return to initial settings. For non-menu screens, press button for right mouse button function.

FREEZE*

Press button to turn ON/OFF the freeze image function.

VOLUME*

Press up to increase or down to decrease speaker volume.

MUTE*

Press button to turn the mute function (speaker sound) ON/OFF.

TIMER*

Press button to turn the menu screen timer ON/OFF. *The timer does not display when the blank function is active.*

ZOOM

Press (+) to increase or (-) to decrease the size of the displayed image.

AUTO*

Press the AUTO button to activate the auto sync function. The message "AUTO IN PROGRESS" will display for several seconds as the projector adjusts the V. POSIT, H.POSIT, H.PHASE, & H. SIZE settings. The Auto Sync function will not operate under the following conditions:

- Initial screen message NO INPUT IS DETECTED or SYNC IS OUT OF RANGE is displayed.
- Freeze and Magnify functions have not been turned off prior to pressing AUTO button.
- Software application running on your computer is not set to maximum screen size prior to pressing AUTO button.

* This button will not function if the message "NO INPUT IS DETECTED" or "SYNC IS OUT OF RANGE" is displayed.

Section 3: Basic Operations

3.1 Projector Startup

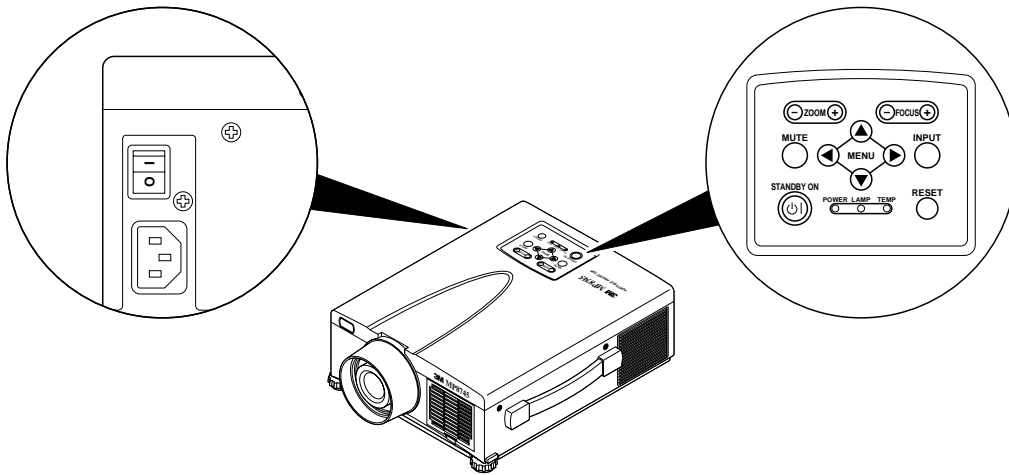









Figure 3.1 Projector Controls

1. **Make all cable connections and line hookups with the power off.**
2. **Turn the POWER SWITCH**  **of the projector on.** The POWER indicator will light up orange.
3. **Press the STANDBY/ON button** . The POWER indicator blinks (green) and then lights (green). The POWER indicator will blink green during warm-up and lamp ignition. When power is turned off, there is a 60 second reset period before the STANDBY/ON button will function again.
4. **Adjust the screen size by pressing the ZOOM button.** 
5. **Adjust the focus by pressing the focus button.** 
Press any other button to make the focus screen disappear.
6. **Turn on all connected equipment.** Refer to section 2.3.
7. **Press the INPUT button**  **on the projector or the INPUT SELECT (VIDEO or RGB) button on the remote to select the source of the signal to be projected on the screen.** The selected signal input is displayed at the bottom right of the screen. The display will show the **last selected input source** before power was turned off.

3.2 Projector Shutdown

1. **Press and hold the STANDBY/ON button**  **for 1 second.** The POWER indicator blinks orange and the lamp turns off. After approximately 1 minute, the fan stops and the indicator stays orange.
2. Turn the **MAIN POWER SWITCH**  of the projector off.

Caution

Do not turn off the POWER SWITCH before pressing the STANDBY/ON button. After the STANDBY/ON button is pressed, the fan rotates for about 1 minute to cool the projector.

3. **Attach lens cap to protect projection lens.**
4. **Disconnect cables if moving projector to new location.**



Section 4: Adjustments and Functions

4.1 How To Use Height Adjustment Feet

Adjust the image elevation using the height adjustment at the front of the projector.

1. Raise the front end of the projector so the feet are not touching the table top.
2. Push the lock button to unlock the foot.
3. Extend or retract each foot to the desired height.
4. Release the lock button to lock the foot into position.
5. For fine adjustments, rotate each foot.

! Caution

Do not unlock the foot adjusters if the projector is not supported. If the foot adjusters do not lock completely, turn the foot adjusters slightly before locking.

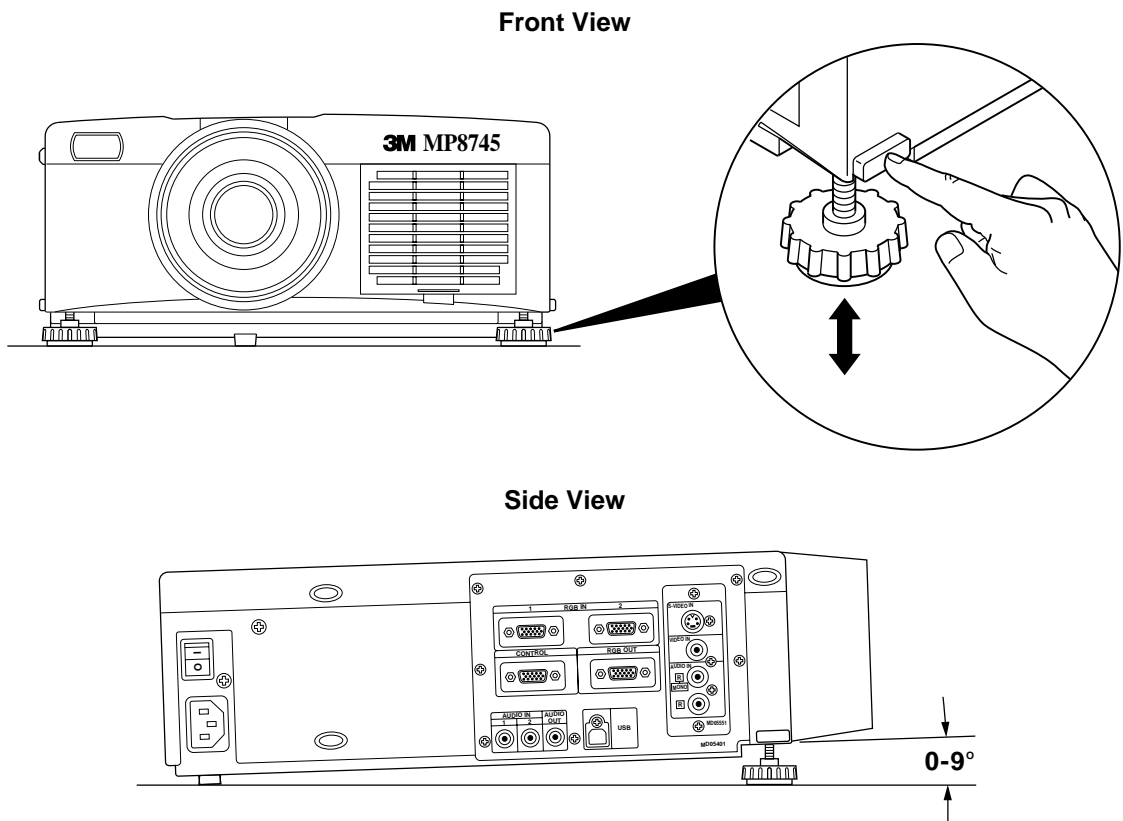

Figure 4.1 Height Adjustment

4.2 Plug & Play Function

This projector is VESA DDC 1/2B compatible. Plug & play is possible by connecting to a computer that is VESA DDC (Display Data Channel) compatible. Plug & play is a system configured with peripheral equipment including a computer and display, and a compatible operating system.

✓ Note

Use the RGB cable included with this projector when using plug & play. With other cables, pins (12) - (15) are sometimes not connected (effective only for RGB1).

4.3 Freeze Function

The Freeze function is used to display (freeze) a single frame of the image being projected.

✓ Note

The FREEZE function will turn off during the operation of the MENU, FOCUS, PinP, VOLUME, MUTE, BLANK, MAGNIFY, AUTO or POSITION functions.

4.4 Magnify Function

The Magnify function is used to enlarge a portion of the display image. Press the MAGNIFY (+) button to magnify the center of the displayed image. Press again to magnify to 4x. Press the MAGNIFY (-) button to reduce image size. Press OFF to return to normal image size. To move the display area being magnified, press the POSITION button, then use the DISC PAD to move the magnified area up, down, left or right.

✓ Note

To return to normal display, press the MAGNIFY OFF button. The MAGNIFY function will turn off during the operation of the MENU, FOCUS, PinP, VOLUME, MUTE, BLANK, FREEZE or AUTO functions.

4.5 Picture-in-Picture

The PinP button on the remote control is used to display a video signal image in the RGB signal image. Press the PinP button to display the PinP screen (small size). Press again to increase the screen size (maximum size screen). Press a third time to exit the function and remove the PinP screen.

[small screen size → maximum screen size → OFF]

Both RGB and Video signals must be present for the picture-in-picture function to operate.

1. Select RGB1 or RGB2 input.
2. Start the video input source.
3. Press the PinP button on the remote control to display a small PinP screen in the corner of the projector image. Press the PinP button again to enlarge the size of the screen display to maximum.
4. Press the POSITION button on the remote control to change the location of the PinP screen. *The position of the picture-in-picture screen can also be changed from the Image menu.*
5. Press the PinP button a third time to exit the function and remove the PinP screen from the projector image.

4.6 Menu Navigation

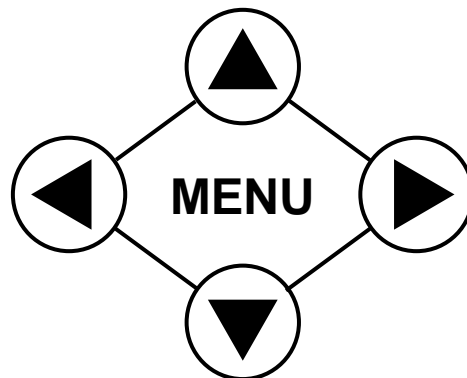

Figure 4.2 Menu Button

1. **Press any MENU button on projector or remote control MENU button.**
On-screen menus are displayed on the screen.
2. **Select the menu to be adjusted using the MENU (◀▶) buttons or DISC PAD.**
Selected Menu is highlighted.
3. **Select the item to be adjusted using the MENU (▲▼◀▶) buttons or DISC PAD.**
Highlighted items may be adjusted.

✓ Note

Separate settings are provided for the VIDEO, RGB1 and RGB2 input terminals. Adjustments are saved after power off.

Factory Default Setting:

To reset a single item from SETUP menu:

1. Select the adjustment item (bright, contrast...).
2. Press the RESET button. **Only the selected item resets.**

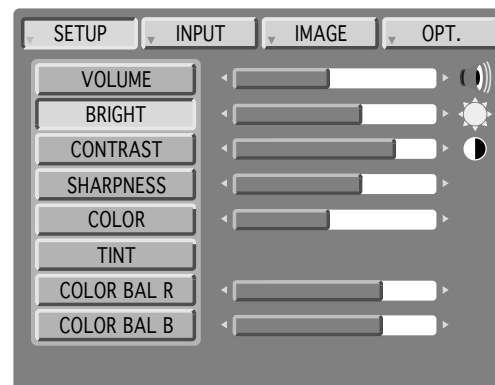

Figure 4.3 Default Settings

4.7 SETUP

The SETUP sub-menu is used to adjust and move the image position. The projector will display either the RGB (Figure 4.4) or Video (Figure 4.5) menu according to the input source being projected.

RGB signal input

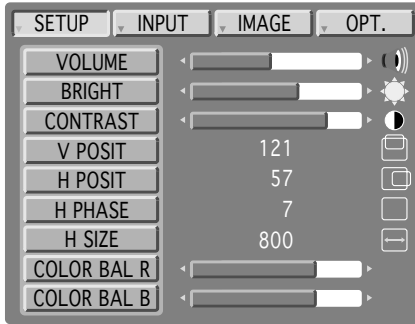

Figure 4.4 RGB Signal

Video signal input

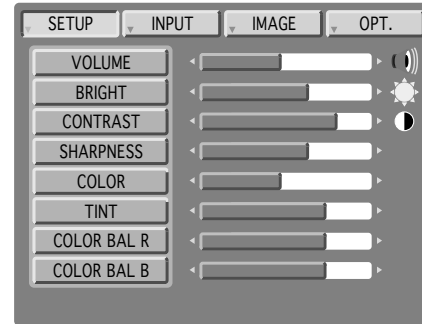

Figure 4.5 Video Signal

Adjustment Item	Details of Adjustment	Freeze On	Magnify On	Both On
VOLUME	Decrease ← → Increase	Adjustable	Adjustable	Adjustable
BRIGHT (BRIGHTNESS)	Dark ← → Bright	Adjustable	Adjustable	Adjustable
CONTRAST	Lower ← → Higher	Adjustable	Adjustable	Adjustable
SHARPNESS	Soft ← → Sharp	Not Adjustable	Adjustable	Not Adjustable
COLOR	Less ← → More	Not Adjustable	Adjustable	Not Adjustable
TINT	Red ← → Green	Not Adjustable	Adjustable	Not Adjustable
V.POSIT (V.POSITION)	Moves the picture up or down.*	Not Adjustable	Not Adjustable	Not Adjustable
H.POSIT (H.POSITION)	Moves the picture left or right.*	Not Adjustable	Not Adjustable	Not Adjustable
H.PHASE	Decreases the picture flicker.*	Not Adjustable	Adjustable	Not Adjustable
H.SIZE	Widens or Narrows the horizontal size of picture.*	Not Adjustable	Not Adjustable	Not Adjustable
COLOR BAL R	Less red ← → More red	Adjustable	Adjustable	Adjustable
COLOR BAL B	Less blue ← → More blue	Adjustable	Adjustable	Adjustable

***Auto Sync Function:** Press the AUTO button on the remote control to engage the automatic sync function. The message "AUTO IN PROGRESS" will display for several seconds as the projector adjusts the V. POSIT, H.POSIT, H.PHASE, & H. SIZE settings.

✓ Note

- TINT cannot be adjusted with a PAL, SECAM, N-PAL or M-PAL video signal input.
- TINT, COLOR and SHARPNESS cannot be adjusted with an RGB signal input.
- V. POSIT, H. POSIT, H. PHASE and H. SIZE cannot be adjusted with a VIDEO signal input.
- Menu operation is not possible during magnify or freeze functions.
- Displaying the Setup menu will cancel the magnify and freeze functions.

4.8 INPUT

The INPUT sub-menu is used to select the RGB or video input source. The RGB values are shown in figure 4.6. The VIDEO values are shown in figure 4.7.

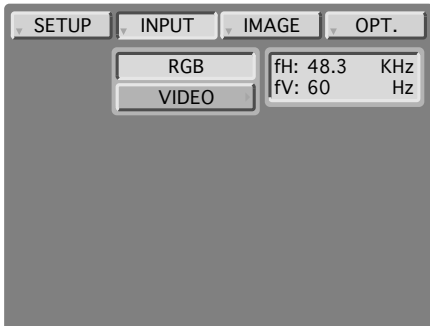

Figure 4.6 Input Menu - RGB

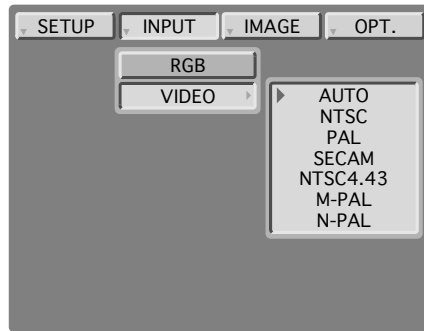

Figure 4.7 Input Menu - Video

Adjustment Area	Value
RGB	Displays the following RGB inputs: fH: horizontal sync frequency fV: vertical sync frequency
Video	Selects the VIDEO signal format Auto, NTSC, PAL, SECAM, NTSC 4.43, M-PAL, N-PAL

4.9 IMAGE

The IMAGE sub-menu is used to change the image characteristics.

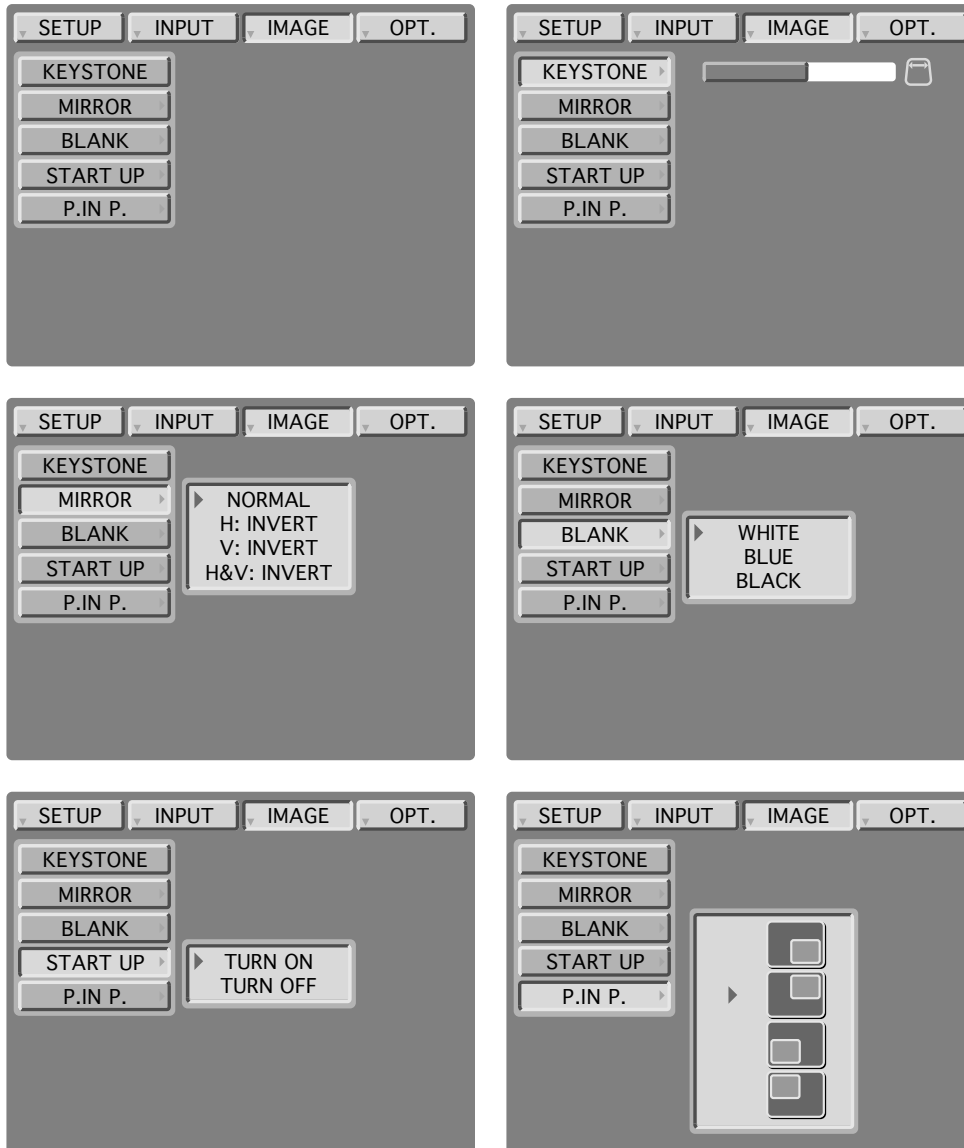
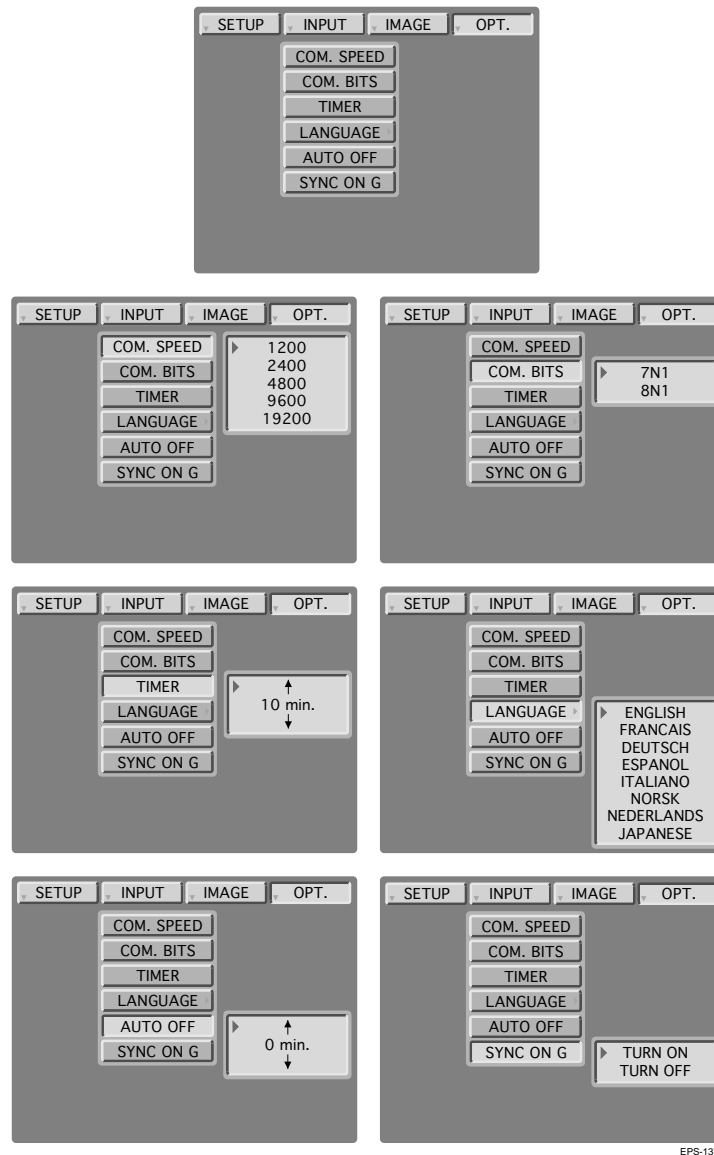

Figure 4.8 Image Adjustment Screens

Adjustment Screen	Value
KEYSTONE	Reduce distortion at bottom of image. \longleftrightarrow Reduce distortion at top of image.
MIRROR	Inverts the picture horizontally or vertically. H: INVERT Inverts the picture horizontally. V: INVERT Inverts the picture vertically. H&V: INVERT Inverts the picture horizontally and vertically.
BLANK	Selects the blank color.
STARTUP	Enable / disable startup screen
P. IN P.	Change the picture in picture screen display position.

4.10 OPT.

The OPT. sub-menu allows you to control communication function.



EPS-137A

Figure 4.9 OPT Adjustment Screens

Adjustment Screen	Value	Default
COM. SPEED	Selects the data speed of transmission.	1200
COM. BITS	Selects the data format of transmission. 7N1... 7 data-bits, No parity, 1 stop bit. 8N1... 8 data-bits, No parity, 1 stop bit.	7N1
TIMER	Sets the timer (0-99 minutes).	—
LANGUAGE	Selects the language on-screen menu. (English, French, German, Spanish, Italian, Norwegian, Netherlands, Japanese)	—
AUTO OFF	Selects how long projector will stay on in minutes, if no input is detected. Select 0 to disable this function.	—
SYNC ON G	Sets the SYNC on G function to ON/OFF (supports older monitors).	

Section 5: Maintenance

5.1 Cleaning the Air Filter

✓ Note

Clean the air filter about every 50 hours, if air is restricted due to dust accumulation on filter, the projector may shut down due to overheating.

1. Turn off the **MAIN POWER** switch of the projector and pull out power cord (1). Let cool for 20 minutes.
2. Push tab (2) and remove the air filter cover (3) from the front of projector.
3. Lift retainer wire (4) and carefully remove foam air filter (5).
4. Vacuum (6) dust and dirt from filter.
5. Re-install air filter and replace air filter door.

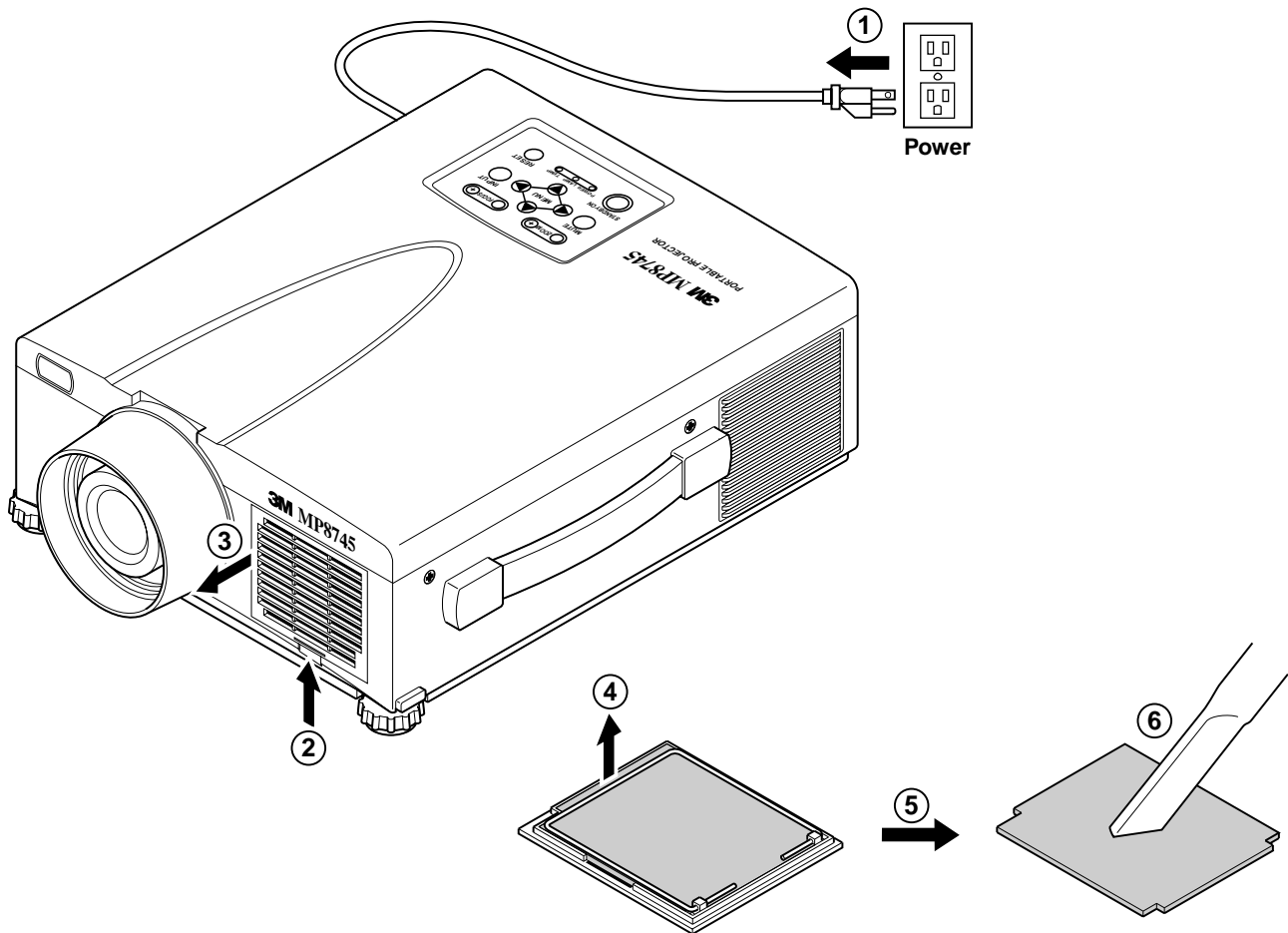

Figure 5.1 Remove Air Filter



Section 6: Lamp

6.1 Lamp

The following symptoms may indicate a lamp in need of replacement:

- LAMP indicator lights up red.
- "CHANGE THE LAMP" message appears on the screen.

✓ **Note**

This lamp contains mercury. Consult your local hazardous waste regulations and **dispose of this lamp in a proper manner.**

6.2 Display Lamp Operation Hours

To determine the lamp operation hours, follow these steps:

1. While the projector is running, press and hold the TIMER button on the remote control for 3 seconds.
2. The operating time of the lamp will be displayed. The message "CHANGE THE LAMP, AFTER REPLACING LAMP RESET THE LAMP TIMER" will appear after the lamp operating hours have reached the end of the normal lamp life. The message "POWER WILL TURN OFF AFTER **20** HOURS" will appear when 20 or less lamp hours remain. The number of hours left until shut down will decrease until **0** hour is reached, then power will be turned off.

✓ **Note**

After normal lamp operating time has expired, the projector will only run for 10 minute intervals when restarted until the lamp is replaced and the lamp timer is reset. The message "CHANGE THE LAMP" will blink at projector start up to remind you to change the lamp.

6.3 Reset Lamp Hours

1. To display the total lamp hours, press and hold for 3 seconds, the RESET button on the projector or Timer button on the remote control.
2. To reset the lamp timer, press the RESET button on the projector or MENU button on the remote while the total lamp hours are displayed. Use the arrow button on the projector or the DISC PAD to select 0 (or CANCEL).

6.4 Replacing the Lamp

⚠ WARNING

To reduce the risk of electrical shock, always turn off projector and disconnect power cord before changing lamp.

⚠ Caution

To reduce the risk of severe burns, allow the projector to cool for at least 30 minutes before replacing the lamp.

To reduce the risk of cuts to fingers and damage to internal components, use caution when removing lamp glass that has failed and shattered into sharp pieces.

✓ Note

For maximum lamp life, do not apply shock, handle or scratch the lamp glass when it is hot. Also, do not use an old or previously used lamp as a replacement lamp.

1. **Remove lamp access door:** The lamp access door is located on the bottom of the machine. Use a screwdriver to unscrew the cover retaining screw (1) and gently remove the cover (2) and set it aside.
2. **Retaining screws:** Use a screwdriver to unscrew the lamp module retaining screws. (3)

✓ Note

All lamp module screws must be loosened. These screws are self-containing screws that cannot be removed from the lamp module or access door.

3. **Remove lamp module:** Carefully slide the lamp module out (4) using steady pressure.

⚠ Caution

To reduce the risk of cuts to fingers from sharp metal fittings and/or decreasing image quality by touching the lens, do not insert hand into the empty lamp compartment when the lamp has been removed.

4. **Insert lamp module:** Carefully insert (4) the new lamp module. Ensure that it is fully seated. Tighten the lamp module retaining screws (3) to secure the lamp module in place.

Insert the hinge tabs on the bottom of the lamp access door, then close and tighten the retaining screw (1) to secure the door.

✓ Note

Reset the lamp operation hours. See section 6.3 for details.

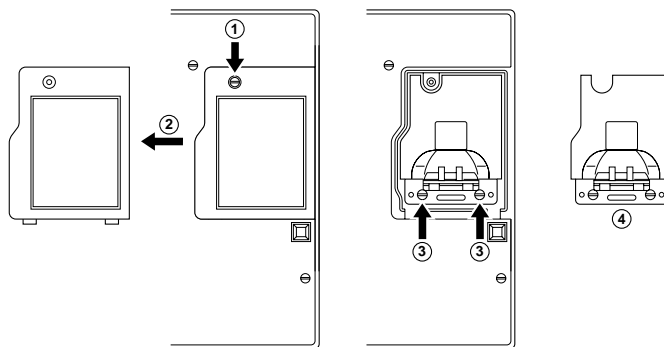

Figure 6.1 Lamp Module



Section 7: Troubleshooting

7.1 Symptom/Solution Table

Symptom	Cause	Solution
Power cannot be turned on.	<ul style="list-style-type: none"> The Main power is not turned on. The power cord is disconnected. 60 seconds have not elapsed since the power was turned off. 	<ul style="list-style-type: none"> Turn the MAIN POWER switch on. Insert the power cord into an AC socket. Wait 60 seconds before turning on power.
No picture and sound.	<ul style="list-style-type: none"> The setting of the input source is not correct. RGB/Video/Audio wiring to projector is not correct. 	<ul style="list-style-type: none"> Set the correct input using the input select button of the projector or the remote control. Connect the cable to correct input/output source.
Sound is heard with no picture.	<ul style="list-style-type: none"> RGB/Video/Audio wiring to projector is not correct. The brightness is set fully to dark. Lens cap is on. 	<ul style="list-style-type: none"> Connect the cable to correct input/output source. Press the MENU button and increase BRIGHTNESS. Remove lens cap.
Picture is displayed with no sound.	<ul style="list-style-type: none"> Audio wiring to projector is not correct. The volume is set to minimum. The unit is muted. PinP is on and audio is switched to VIDEO mode. 	<ul style="list-style-type: none"> Connect the cable to correct input/output source. Press the VOL button to increase Volume. Press the MUTE button. Press VOLUME and move DISC PAD to switch to audio input.
Color is weak and tint is incorrect.	<ul style="list-style-type: none"> The color and tint have been adjusted incorrectly. 	<ul style="list-style-type: none"> Adjust the color and tint correctly.
Picture is dark.	<ul style="list-style-type: none"> The brightness and contrast has not been adjusted correctly. The lamp needs to be replaced. 	<ul style="list-style-type: none"> Adjust the brightness and contrast correctly. Replace the lamp with a new one.
Picture is not clear	<ul style="list-style-type: none"> Projector is out of focus. 	<ul style="list-style-type: none"> Adjust the focus and H PHASE.
LAMP indicator lights red.	<ul style="list-style-type: none"> Lamp will not ignite. 	<ul style="list-style-type: none"> Turn off power and let cool for 20 minutes, then restart. If problem persists call your dealer.
LAMP indicator blinks red.	<ul style="list-style-type: none"> Air filter door on bottom of case is open. 	<ul style="list-style-type: none"> Ensure air filter door is closed.
TEMP indicator lights red.	<ul style="list-style-type: none"> Temperature inside projector is too hot. 	<ul style="list-style-type: none"> Clear blocked ventilation holes. Clean air filter.

7.2 Message/Solution Table

Error Message Displays	Cause	Solution
NO INPUT IS DETECTED.	The projector is not detecting a signal.	Check cable connections to input device. Input device not connected to this input mode, switch to next mode.
SYNC IS OUT OF RANGE.	The horizontal frequency of input signal exceeds projector capability.	Switch projector to correct resolution. See Appendix A.5
CHANGE THE LAMP. CALL A MAINTENANCE PERSON.	Nearing end of normal lamp operation time.	Change the projector lamp and reset the lamp operation hours to zero.
CHANGE THE LAMP. CALL A MAINTENANCE PERSON. THE POWER WILL TURN OFF AFTER *hr.	Remaining lamp operation time = 20 hours or less. *Indicates number of hours until power turns off automatically.	Change the projection lamp and reset the lamp operation hours to zero.
CHANGE THE LAMP. (Blinking message)	Normal lamp operating time has expired. Safety feature shuts projector down after 10 minutes.	Change the projector lamp and reset the lamp operation hours to zero.



Section 8: Accessories

8.1 Service Information

For product information, product assistance, service information, or to order accessories, please call:

In U.S. or Canada: **1-800-328-1371**

In other locations, contact your local 3M Sales office.

Accessories

Part Number

Ultra-high performance lamp module, 190 W	78-6969-8588-3
Power cord (US)	26-1011-8852-7
Power cord (UK)	78-8118-3304-1
Power cord (Germany)	78-8118-3303-3
VGA cable	78-8118-3401-5
MAC adapter	26-1011-3308-2
S-video cable	26-1011-3419-0
3-conductor video/audio cable	78-8118-3306-6
Serial mouse cable	78-8118-3426-2
PS/2 mouse cable	78-8118-3424-7
ADB mouse cable	78-8118-3425-4
Stereo mini jack cable	26-1012-0683-2
Remote Control	78-8118-3534-3

Not Included with Basic Packet

Part Number

Ceiling mount	78-6969-8748-2
Adjustable height suspension	78-6969-8312-7
Shipping case	78-6969-8584-1
Soft carry case	78-6969-8585-8
RS-232 control cable	78-8118-3312-4
USB mouse cable	78-8118-8186-7
Document Camera - 120 VAC 60 Hz (optional)	78-6969-8578-3
Document Camera - 220 VAC 50 Hz (optional)	78-6969-8724-3

How to Order

Please order these parts through your dealer, or contact 3M Customer Service at the following number:

In U.S. or Canada: **1-800-328-1371**

In other locations, contact your 3M Sales office.

The contents of this manual are subject to revision without prior notice.

3M assumes no responsibility for the infringement of special rights of a third party or other rights that may arise out of the information contained in this manual.

Reproduction of this manual in any form without prior permission is strictly prohibited.

3M will replace the manual if any pages are missing or collated incorrectly.



Appendix: Technical Information

Table of Contents

- A.1 Technical Specifications
- A.2 Dimensions
- A.3 Projector-to-Screen Distance
- A.4 Connection to the Video Signal Terminal
- A.5 Connection to the RGB Signal Terminal
- A.6 Indicator Status
- A.7 Connection to the Control Signal Terminal

A.1 Technical Specifications

✓ Note

All specifications are subject to change without notice.

Product name		Multimedia projector
Model Name		MP8745
Display system		3 LCD panels, RGB shutter system.
Liquid crystal panel	Panel size	33 mm (1.3 in.)
	Drive system	TFT active matrix
	Number of pixels	786,432 pixels (V1024 × H768) per panel. 2.3 million total pixels with 3 panels.
Lens		F/Number: F/1.7 – F/2.3 Focal Length: F = 49 – 64 mm (2 in. – 2.5 in.)
Lamp		Ultra-high brightness lamp 190W, UHB
Speaker (stereo)		2 x 1 watt
Power supply		AC100 ~ 120V, 3.7A / AC220 ~ 240V, 1.5A (Universal)
Power consumption		370W
Operating temperature range		32° ~ 95°F (0° ~ 35°C)
Dimensions		11.5 in. (W) x 5 in. (H) x 13.8 in. (D) (D) Does not include lens. 289 mm (W) x 124 mm (H) x 345 mm (D)
Weight		5.9 kg (13 lbs.)
Input/Output terminal	video signal input terminal	S VIDEO : Mini DIN 4pin terminal VIDEO : RCA Jack terminal AUDIO : RCA Jack terminal
	RGB input/output signal terminal	RGB signal : D-sub 15pin (Female) AUDIO : Stereo mini jack
	Control terminal	D-sub 15pin (Male)

A.2 Dimensions

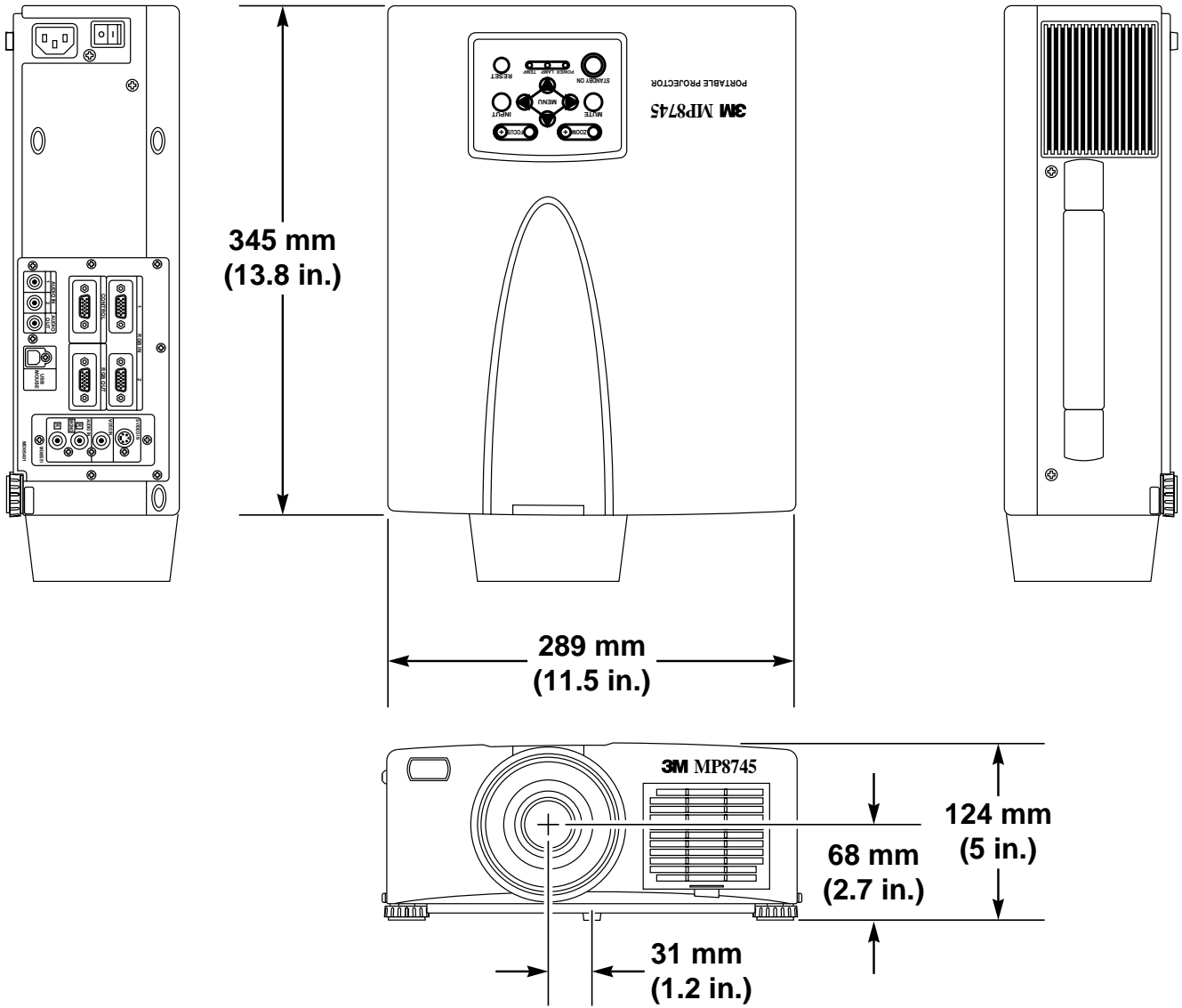

A.3 Projector-to-Screen Distance

Example of the Multimedia projector and screen installation. Determine picture size and projection distance as shown below.

Screen Size			Distance to Screen	
Width	Height	Diagonal	Minimum	Maximum
81 cm (32 in.)	61 cm (24 in.)	102 cm (40 in.)	140 cm (4.6 ft)	186 cm (6.1 ft)
122 cm (48 in.)	91 cm (36 in.)	152 cm (60 in.)	216 cm (7.1 ft)	290 cm (9.5 ft)
163 cm (64 in.)	122 cm (48 in.)	203 cm (80 in.)	290 cm (9.5 ft)	384 cm (12.6 ft)
203 cm (80 in.)	152 cm (60 in.)	254 cm (100 in.)	366 cm (12.0 ft)	485 cm (15.9 ft)
244 cm (96 in.)	183 cm (72 in.)	305 cm (120 in.)	448 cm (14.7 ft)	588 cm (19.3 ft)
305 cm (120 in.)	229 cm (90 in.)	381 cm (150 in.)	558 cm (18.3 ft)	716 cm (23.5 ft)
406 cm (160 in.)	305 cm (120 in.)	508 cm (200 in.)	741 cm (24.3 ft)	981 cm (32.2ft)

✓ Note

These sizes are $\pm 1\%$. This is due to variations in the manufacture of the lens. If you are close to one of the endpoints you should verify with your unit that the image is the proper size at the proper distance.

A.4 Connection to the Video Signal Terminal

a) Input signal

S-VIDEO signal		Luminance signal	1.0Vp-p, 75 Ω termination
		Chrominance signal	0.286Vp-p (burst signal), 75 Ω termination
VIDEO signal			1.0Vp-p, 75Ω termination
AUDIO signal	Input		200mVrms, 20 kΩ below (MAX 3.0Vp-p)
	Output		0~200mVrms, 1k Ω

b) Signal input terminal

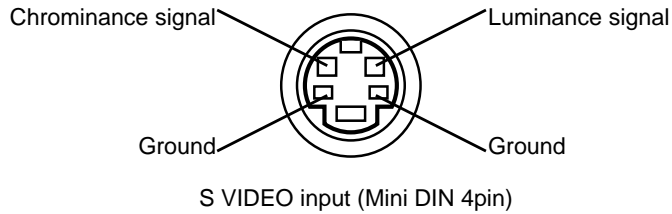

✓ Note

Video input signal terminals have priority in the following order:

1. S-VIDEO input terminal
2. RCA jack (composite) input terminal

Audio sound from input devices is output to the RGB/Video out jack.

A.5 Connection to the RGB Signal Terminal

a) Input signal / Output signal

Video signal		Analog 0.7Vp-p 75 Ω termination (Positive polarity)
Horizontal sync signal		TTL level (Positive/negative polarity)
Vertical sync signal		TTL level (Positive/negative polarity)
Composite sync signal		TTL level
Audio signal	Input	200mVrms, 20k Ω below (MAX 3.0Vp-p)
	Output	0 ~ 200mVrms, 1k Ω

b) Signal input terminal / output terminal

1	Video signal (Red)	9	No Connection
2	Video signal (Green)	10	Ground
3	Video signal (Blue)	11	No Connection
4	No Connection	12	SDA (DDC 1/2B)
5	No Connection	13	Horizontal/Composite sync signal
6	Ground (for R)	14	Vertical sync signal
7	Ground (for G)	15	SCL (DDC 1/2B)
8	Ground (for B)		

c) **Example of computer signal**

Resolution HxV	Refresh Rate	Horizontal Frequency	Standard Type	Note	Display Dots HxV
640 x 350	85.1 Hz	37.9 kHz	VESA	VGA-1	1008 x 560
640 x 400	56.4 Hz	24.8 kHz		NEC PC9800	1024 x 640
640 x 400	85.1 Hz	37.9 kHz	VESA	VGA-2	1008 x 640
640 x 480	85.0 Hz	43.3 kHz	VESA	VGA-3 (85 Hz)	1024 x 768
640 x 480	59.9 Hz	31.5 kHz	VESA	VGA-3	1024 x 768
640 x 480	66.7 Hz	35.0 kHz		MAC 13"	1024 x 768
640 x 480	72.8 Hz	37.9 kHz	VESA	VGA-3 (72 Hz)	1024 x 768
640 x 480	75.0 Hz	37.5 kHz	VESA	VGA-3 (75 Hz)	1024 x 768
720 x 400	85.0 Hz	37.9 kHz	VESA	TEXT	1008 x 640
800 x 600	56.3 Hz	35.2 kHz	VESA	SVGA (56 Hz)	1000 x 750
800 x 600	60.3 Hz	37.9 kHz	VESA	SVGA (60 Hz)	1000 x 750
800 x 600	72.2 Hz	48.1 kHz	VESA	SVGA (72 Hz)	1000 x 750
800 x 600	75.0 Hz	46.9 kHz	VESA	SVGA (75 Hz)	1000 x 750
800 x 600	85.1 Hz	53.7 kHz	VESA	SVGA (85 Hz)	1000 x 750
832 x 624	74.5 Hz	49.7 kHz		MAC 16"	1024 x 768
1024 x 768	60.0 Hz	48.4 kHz	VESA	XGA (60 Hz) Compressed	1024 x 768
1024 x 768	70.1 Hz	56.5 kHz	VESA	XGA (70 Hz) Compressed	1024 x 768
1024 x 768	75.0 Hz	60.0 kHz	VESA	XGA (75 Hz) Compressed	1024 x 768
1152 x 768	75.0 Hz	67.5 kHz	VESA	SXGA (75 Hz)	1024 x 756
1280 x 960	60.0 Hz	60.0 kHz	VESA	SXGA (60 Hz)	1024 x 768
1280 x 1024	60.0 Hz	64.0 kHz	VESA	SXGA (60 Hz)	960 x 768
1280 x 1024)	75.0 Hz	80.0 kHz	VESA	SXGA (75 Hz)	960 x 768

**Note 1: MAC adapter is necessary to set the resolution mode.
 Projector is compatible with 13 inch mode and 16 inch mode.
 Set all dip switches OFF except those indicated below.
 MAC 13" mode = switch 1 and 2 are ON
 MAC 16" mode = switch 2 and 4 are ON**

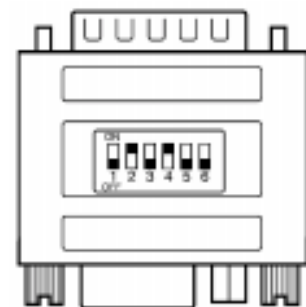

(Example of 16 inch mode)

Note 2: Some input sources may not be displayed properly because they are not compatible with the projector.

A.6 Indicator Status

The POWER, LAMP and TEMP indicators will light or blink in the following cases:

POWER INDICATOR	LAMP INDICATOR	TEMP INDICATOR	MEANING	REMEDY
Lights orange	Turns off	Turns off	Standby mode	Normal
Flashes green	Turns off	Turns off	During warm up	Normal
Lights green	Turns off	Turns off	During operation	Normal
Flashes orange	Turns off	Turns off	During cooling down	Normal
Lights red	Lights red	Turns off	Lamp does not light	Turn off power and let projector cool for 45 minutes.
Lights red	Flashes red	Turns off	Lamp or lamp cover loose or missing.	Fully insert lamp module or lamp cover and secure with retaining screws.
Lights red	Turns off	Flashes red	Cooling fan not operating.	Contact your dealer.
Flashes red	Flashes red	Turns off	The lamp operating hours have reached maximum operating hours.	Replace the lamp.

***When the LAMP indicator lights or blinks, turn the power off. If the problem persists, contact your dealer.**

A.7 Connection to the Control Signal Terminal

a) Mouse emulation

- (1) While the projector and computer are turned OFF, connect the projector and the mouse terminal of computer using an appropriate cable (PS/2, Serial or ADB).
- (2) Turn ON the projector.
- (3) Turn ON the computer.
- (4) Select the correct mouse driver for the application. See computer's User Manual for this procedure.

✓ Note

In some Notebook computers with an internal pointing device, mouse emulation will not work unless the internal pointing device is disabled. In this case, disable the internal pointing device in BIOS setting. Check the computer's manual for procedure to follow to disable internal pointing device in BIOS setting.

⚠ Caution

Turn off the power to both the projector and computer before connecting. Connect the computer to the control terminal of the projector using the appropriate cable.

PS/2 mouse

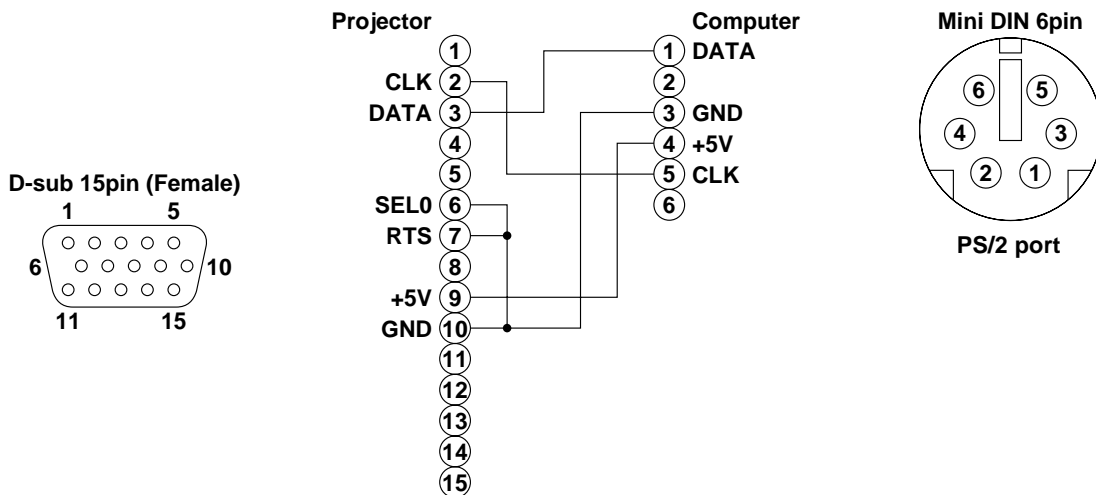

ADB mouse

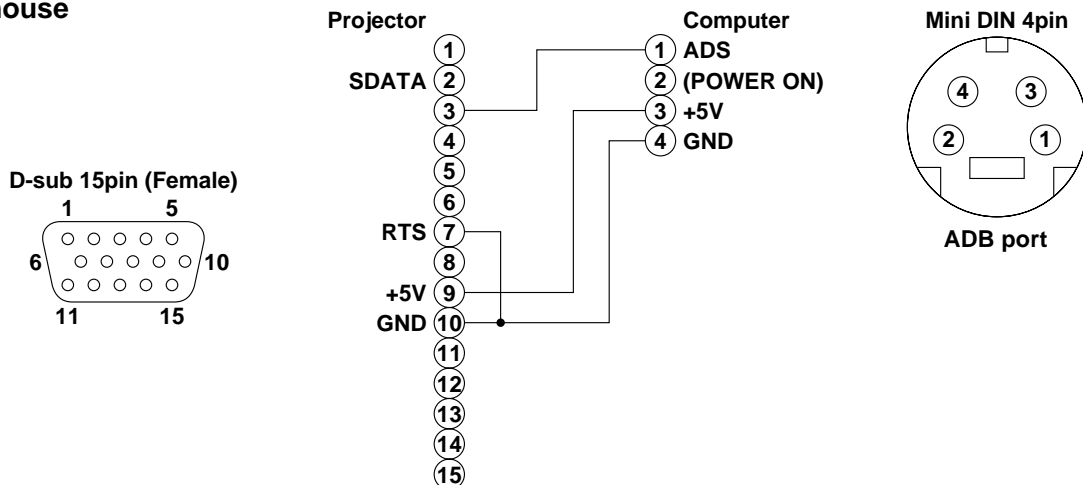

A.7 Connection to the Control Signal Terminal (continued)

Serial mouse

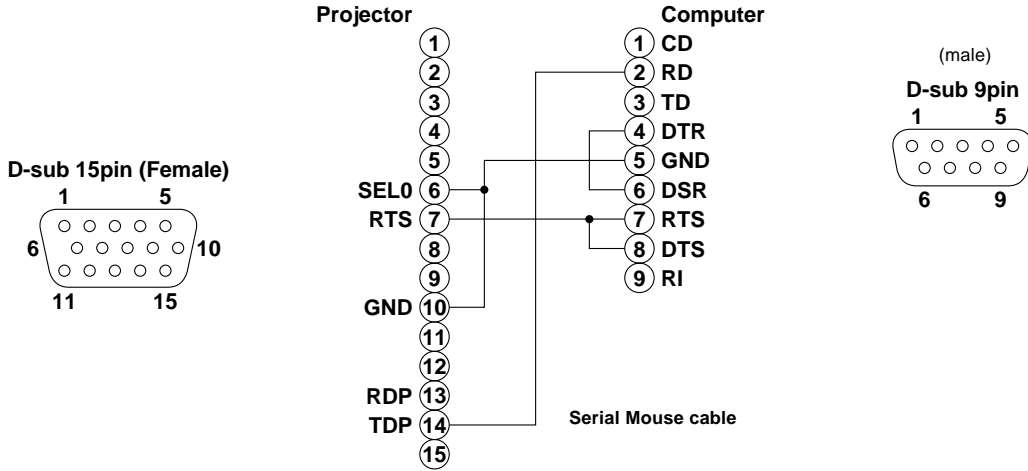

RS-232 Control Cable (not included with basic packout)

This cable is used to directly control the projector without using the Remote Control or Operator's Panel.

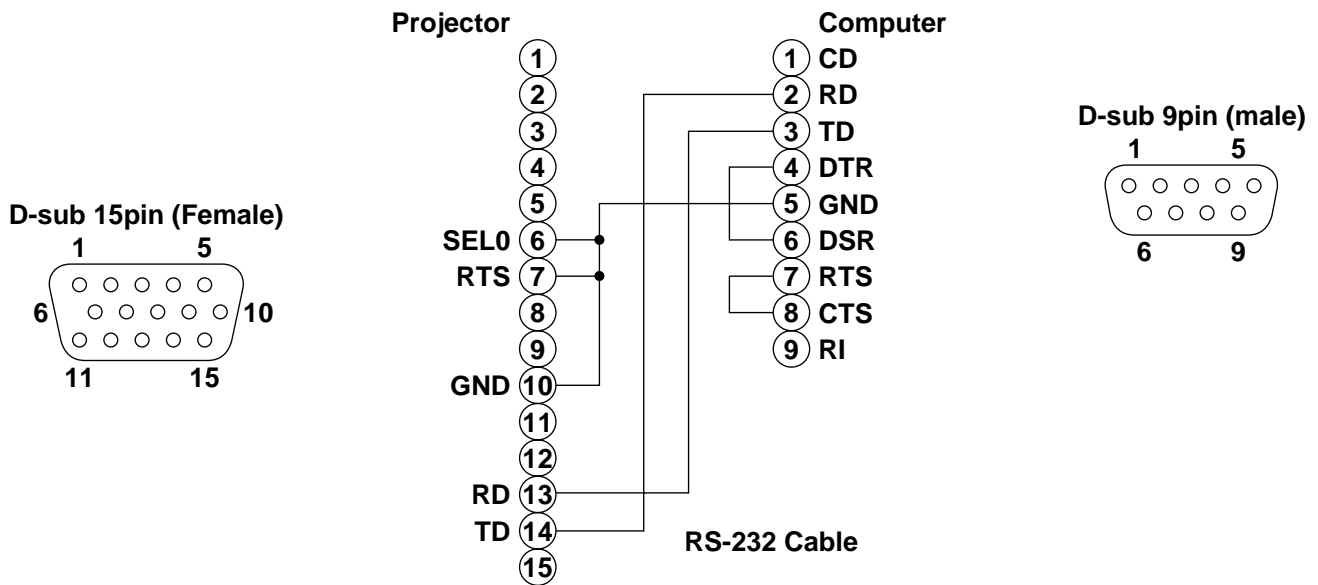

A.7 Connection to the Control Signal Terminal (continued)

USB Mouse Cable

This cable is used to connect the projector and computer to allow computer mouse control via the projector's remote control buttons. Connect the cable, select the input source where the computer is to be connected and start the mouse functions.

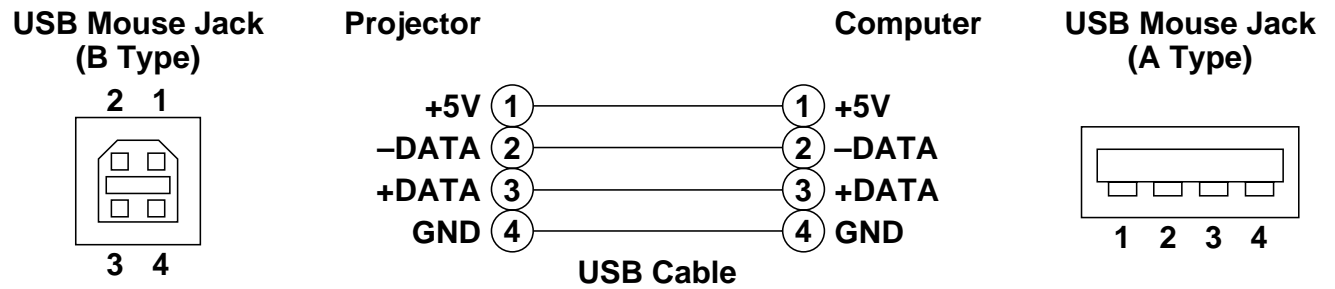

✓ Note

Some laptop computers with a built-in pointing device (track ball) may not recognize the external mouse. In this case, change the BIOS (system setup) so that an external mouse can be selected. Some computers may not have the necessary utility program to operate a mouse. Refer to the computer hardware manual.

Serial Command Codes

All numbers in this document are in Hexadecimal. You must send at the same communication setting as the projector and use a null modem serial cable to connect to the projector.

There are four types of messages: 1) ASK, 2) REPLY, 3) SET and 4) DEFAULT.

Ask Code:

User:

20	XX
----	----

XX is the attribute you are checking.

Projector:

1Y	XX	Y bytes of data
----	----	-----------------

This is a reply code. The Y is the number of extra bytes that come after the command.

The XX is the same as in the Ask code.

Set Code:

User:

3Y	XX	Y bytes of data
----	----	-----------------

XX is the attribute you are checking. The Y is the number of bytes for the data.

Projector:

1Y	XX	Y bytes of data
----	----	-----------------

This is a reply code. The Y is the number of extra bytes that come after the command.

The XX is the same as in the Set code.

Default Code:

User:

40	XX
----	----

XX is the attribute you are checking.

Projector:

1Y	XX	Y bytes of data
----	----	-----------------

This is a reply code. The Y is the number of extra bytes that come after the command.

The XX is the same as in the Ask code.

Errors:

For an error, the projector will reply with the same code that was sent but with a 0 in the first nibble.

Serial Command Code Table

Function	Command Code	# Bytes	Data Code	Meaning
Mouse	05	1	00 01-7F	Stop mouse function Enable mouse function
Communication	06	1	0X 1X X0 X1 X2 X3 X4	8N1 7N1 1200 bps 2400 bps 4800 bps 9600 bps 19200 bps
Power	11	1	3E 3F	Power off Power on
Zoom	12	1	01-3F 41-7F	Zoom + Zoom -
Focus	13	1	01-3F 41-7F	Focus + Focus -
Mirror	14	1	00 01 02 03	Normal H Invert V Invert H & V Invert
Magnify	15	Set Command 1 Ask Command 1	01 7F 00 01	Magnify+ Magnify- Magnify Off Magnify On
Freeze	16	1	00 01	Freeze Off (normal display) Freeze On
Input	21	1	11 21 22	Video RGB 1 RGB 2
Video Type	22	2	00 00 00 01 00 02 00 03 00 04 00 05 00 06	Auto NTSC PAL SECAM NTSC 4.43 M-PAL N-PAL
Volume	23	1	00-24	00 - 24 is high end of scale
Mute	24	1	00 01	Mute off Mute on
Brightness	31	3	00 00 00 - 00 00 24	24 is high end of scale
Contrast	32	3	00 00 00 - 00 00 24	24 is high end of scale

Serial Command Code Table (con't)

Function	Command Code	# Bytes	Data Code	Meaning
Color	33	3	00 00 00 - 00 00 24	24 is high end of scale
Tint	34	3	00 00 00 - 00 00 24	24 is green end of scale
Sharpness	35	3	00 00 00 - 00 00 24	24 is sharp end of scale
H. Phase	37	3	00 00 00 - 00 00 24	
H. Position	38	4	00 00 00 01 00 00 00 7F	00 01 is 1 step up
H. Size	36	4	00 00 00 00 00 00 00 7F	7F is wide end of scale
V. Position	3A	3	00 00 00 01 00 00 00 7F	00 01 is 1 step up
Color Balance R	3B	3	00 00 00 00 00 24	24 is more red
Color Balance B	3D	3	00 00 00 00 00 24	24 is more blue
Auto Adjust	3C	1	00 07	Start Stop
Blank	41	1	0X 1X X=8 X=9 X=F	Blank off Blank on Black Blue White
Reveal	42	1	X1 X4	Reveal down Reveal right X is down and right is 0 - 7 with 7 being the fastest

Important Notice

All statements, technical information, and recommendations related to 3M's products are based on information believed to be reliable, but the accuracy or completeness is not guaranteed. Before using this product, you must evaluate it and determine if it is suitable for your intended application. You assume all risks and liability associated with such use. Any statements related to the product which are not contained in 3M's current publications, or any contrary statements contained on your purchase order shall have no force or effect unless expressly set forth in a written agreement signed by an authorized officer of 3M.

Warranty and Limited Remedy. This product will be free from defects in material and manufacture for a period of two years from the date of purchase. **3M MAKES NO OTHER WARRANTIES INCLUDING, BUT NOT LIMITED TO, ANY IMPLIED WARRANTY OF MERCHANTABILITY OR FITNESS FOR A PARTICULAR PURPOSE.** If this product is defective within the warranty period stated above, your exclusive remedy shall be, at 3M's option, to replace or repair the 3M product or refund the purchase price of the 3M product.

Limitation of Liability. Except where prohibited by law, 3M will not be liable for any loss or damage arising from this 3M product, whether direct, indirect, special, incidental or consequential regardless of the legal theory asserted.

Let us help you make the most of your next presentation. We offer everything from presentation supplies to tips for better meetings. And we're the only transparency manufacturer that offers a recycling program for your used transparencies. For late-breaking news, handy reference and free product samples, call us toll-free in the continental United States and Canada, 24 hours a day, or visit our Internet Website.

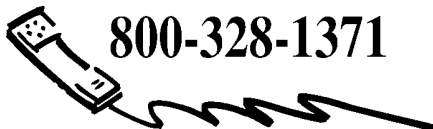
**800-328-1371****<http://www.3m.com/meetings>
e-mail: meetings@mmm.com**

3M Austin Center
Building A145-5N-01
6801 River Place Blvd.
Austin, TX 78726-9000

3M Canada
P.O. Box 5757
London, Ontario
N6A 4T1

3M Mexico, S.A. de C.V.
Apartado Postal 14-139
Mexico, D.F. 07000
Mexico

3M Europe
Boulevard de l'Oise
95006 Cerge Pontoise Cedex
France

*Printed on 50% recycled wastepaper,
including 10% post-consumer*
Litho in USA
Copyright ©1999 3M IPC.
All Rights Reserved
78-6970-8993-2 Rev. A